



HOW DO I CALCULATE THE VOLUME OF MY CONTAINMENT DIKE?

SITUATION 1:

One tank in the diked area

***Note that the length, width and height of the dike must be measured on the inside, not the outside of the dike.**

- 1) Measure the length of the dike wall _____ (in feet) = "a" in the formula
- 2) Measure the width of the dike wall _____ (in feet) = "b" in the formula
- 3) Measure the height of the dike wall _____ (in feet) = "c" in the formula

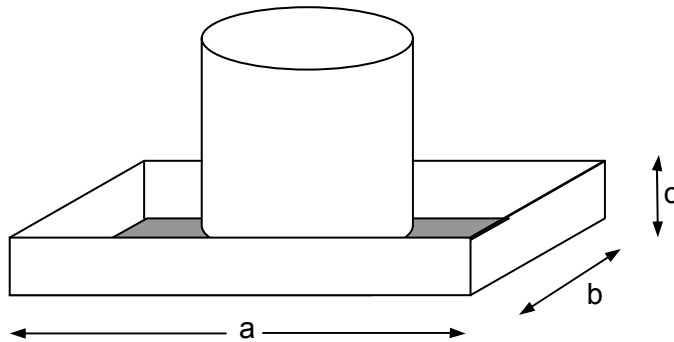

Step 1: Multiply the size of your tank (in gallons) by the number indicated to calculate the minimum amount that your dike is required to hold in gallons:

$$(\text{size in gallons}) \quad \underline{\hspace{2cm}} \quad \times \quad 1.1 \quad = \quad \underline{\hspace{2cm}}$$

Step 2: Multiply "a" times "b" times "c" to determine the volume of the dike in cubic feet:

$$\underline{(a)} \quad \underline{\hspace{1cm}} \quad \times \quad \underline{(b)} \quad \underline{\hspace{1cm}} \quad \times \quad \underline{(c)} \quad \underline{\hspace{1cm}} \quad = \quad \underline{\hspace{2cm}} \quad \text{cubic feet}$$

Step 3: Divide the answer from step 2 by the conversion factor below to convert the size of the dike in cubic feet to gallons:

$$\underline{\hspace{2cm}} \quad / \quad 0.1337 \quad = \quad \underline{\hspace{2cm}} \quad \text{gallons}$$

(answer from step 2)

Step 4: Compare the answers in Step 1 and Step 3 to determine if the dike will hold 110% of the volume of the tank. **The answer in Step 3 must be equal to or greater than the answer in Step 1.**

over

SITUATION 2:

More than one tank within the diked area

***Note that the length, width and height of the dike must be measured on the inside, not the outside of the dike.**

- 1) Measure the length of the dike wall _____ (in feet) = "a" in the formula
- 2) Measure the width of the dike wall _____ (in feet) = "b" in the formula
- 3) Measure the height of the dike wall _____ (in feet) = "c" in the formula

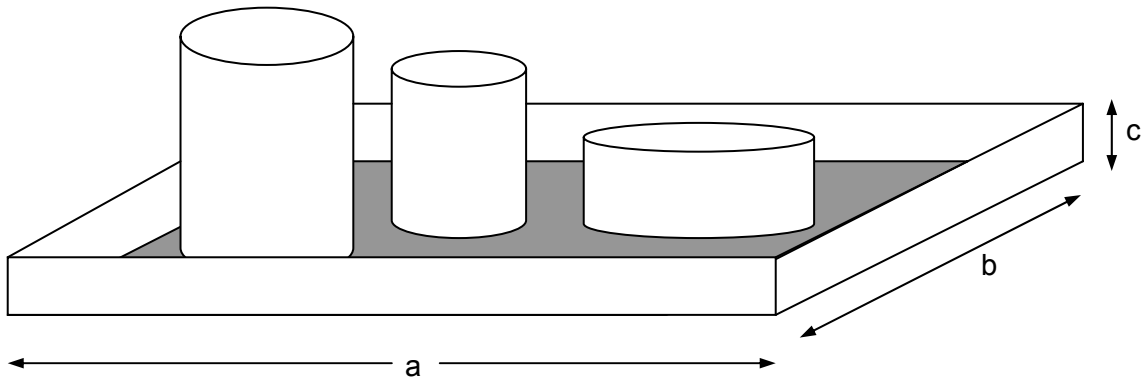

Step 1: Multiply the size of your largest tank (in gallons) by the number indicated to obtain the minimum amount that your dike is required to hold in gallons: (Please note that if you have 2 or more tanks siphoned together, you must use the total gallons of all tanks siphoned together.)

_____ x 1.1 = _____

Step 2: Multiply "a" times "b" times "c" to determine the containment volume of the dike in cubic feet:

(a) _____ x (b) _____ x (c) _____ = (f) _____ cubic feet

Step 3: Determine the displacement of other tanks within the diked area by multiplying the height of the dike wall "c" x (1/2 the diameter of each additional tank within the dike)² x 3.14. This calculation must be repeated for each additional tank within the diked area.

(c) _____ x (1/2 diameter of tank)² x 3.14 = _____
 (c) _____ x _____ x 3.14 = _____
 (c) _____ x _____ x 3.14 = _____
 Total = (h) _____

Step 4: Subtract the results from step 3 from the results in step 2 to determine the total available volume of the diked area in cubic feet.

(f) _____ - (h) _____ = (i) _____
 (Step 2) (Sum of Step 3)

Step 5: Divide the answer from step 4 by the conversion factor below to convert the size of the dike in cubic feet to gallons:

(i) _____ / 0.1337 = _____ (gallons)
 (answer from step 4)

Step 6: Compare the answers in Step 1 and Step 5 to determine if the dike will hold 110% of the volume of the tank. **The answer in Step 5 must be equal to or greater than the answer in Step 1.**